

SPHERE_360

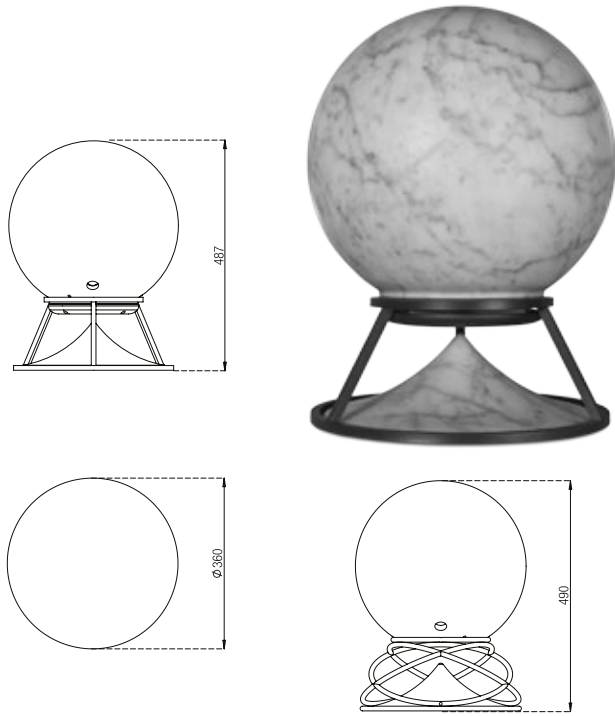

FULL RANGE SOUND OUTPUT

- Speaker type**
6" dual-concentric speaker
- Nominal impedance**
8 Ω
- Crossover**
two way on board
- Frequency range**
50-20.000 Hz (-6dB)
- Sensitivity (1W-1m)**
89 dB
- Speaker Peak Power**
300W
- Speaker RMS Power**
150W
- Recommended amplifier power**
200W (Class D)

SUBWOOFER SOUND OUTPUT

- Speaker type**
6" Woofer
- Nominal impedance**
8 Ω
- Crossover**
no crossover on board - DSP needed (HP 35 Hz 12dB/oct min; LP 120 Hz 12 dB/oct min)
- Frequency range**
42-150 Hz (-6dB)
- Sensitivity (1W-1m)**
89 dB
- Speaker Peak Power**
300W
- Speaker RMS Power**
150W
- Recommended amplifier power**
200W (Class D)

LAMPS SPECS (optional)

- Light source**
LED module: 1x7W
- Rated output**
7W
- Power supply**
90-260V

SPECIFICATIONS

- Material**
concrete, marble, travertine, terracotta, concrete, alternative stones
- Base material**
stainless steel, brass, painted steel
- Dimensions**
Ø 360 x 490 mm
- Weight**
31 kg (marble)

Unpacking: to remove the Sphere from the shipping box carefully follow these steps

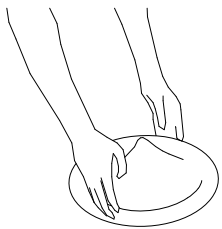

1. Gently lift the deflector from the packaging, turn it and place into position on the floor.

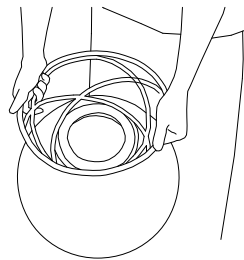

2. Hold the metal base attached to the sphere firmly and gently pull it out of the box.

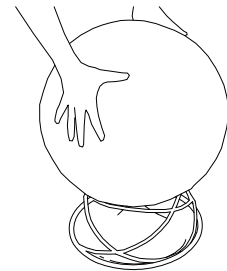

3. Turn the sphere and place it into position on top of the deflector.

Output cable: Sphere's bases can have two types of output cable:

- **Horizontal Output** is suitable for both indoor and outdoor installations when cable arrives horizontally on the side of the base.
- **Vertical Output Underground** is particularly recommended for outdoor installations where cables run underground in order not to create problems during garden maintenance.

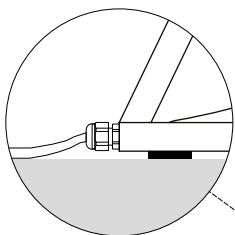

Horizontal Output

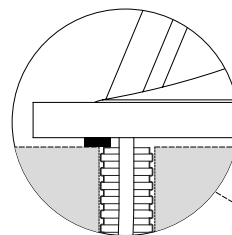
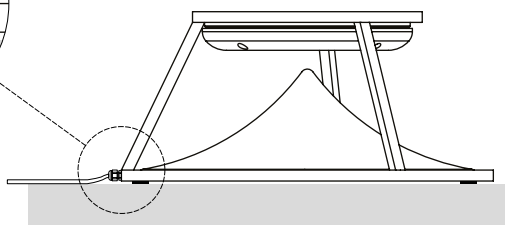

Vertical Output Underground

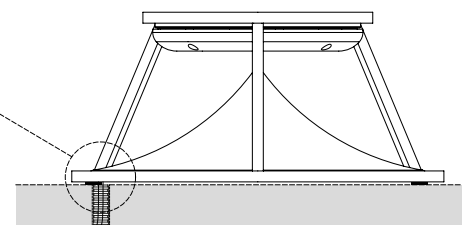

Lighting Mood Output (optional): the Lighting Mood bases have two cables coming out from below, the acoustic and the electrical one; refer to the following scheme for installation:

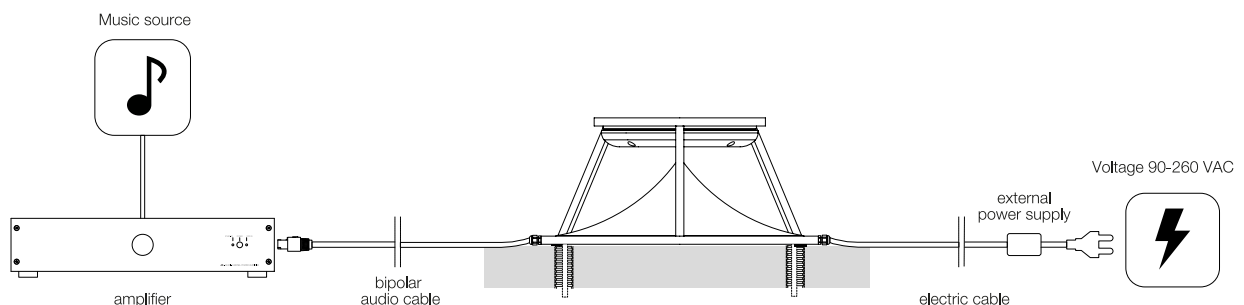

Diffusion and directionality: Spheres are characterized by a dual-concentric 6" transducer, where the mid-woofer and the tweeter share the same axis, to achieve a virtually punctiform source, linear and time coherent, which, combined with the deflection system, ensures an ideal omnidirectional emission. The result is a very natural sound, not constrained to any fixed and obligated listening positions, with an amazing quality and clarity unusual in outdoor environments. It is recommended to place these modules, either indoor or outdoor, directly on the floor; indoor it is usually recommendable to position them at least 0,6-1 meter from each wall to enhance soundstage and clarity.

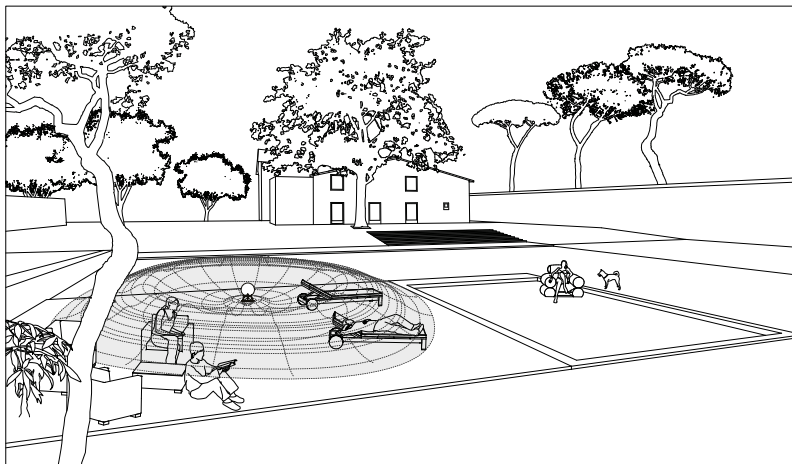

Installation precautions: When installing the Sphere outdoor in presence of an irrigation system make sure water **DOES NOT** directly reach the speaker below, either from the bass reflex hole or bouncing on the deflector.

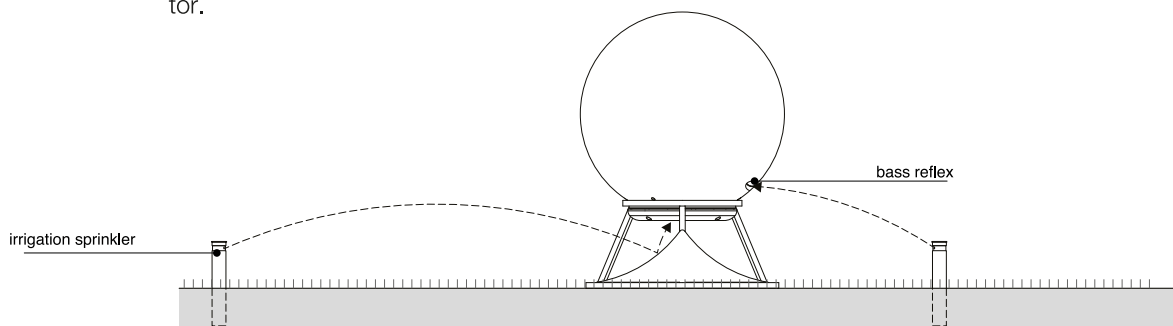

Anti-theft system: When installing the Sphere outdoor, especially in public spaces, specifically designed anti-theft systems are available on demand to secure the module to the ground. In the case of outdoor installations on grass or soil proceed as follows:

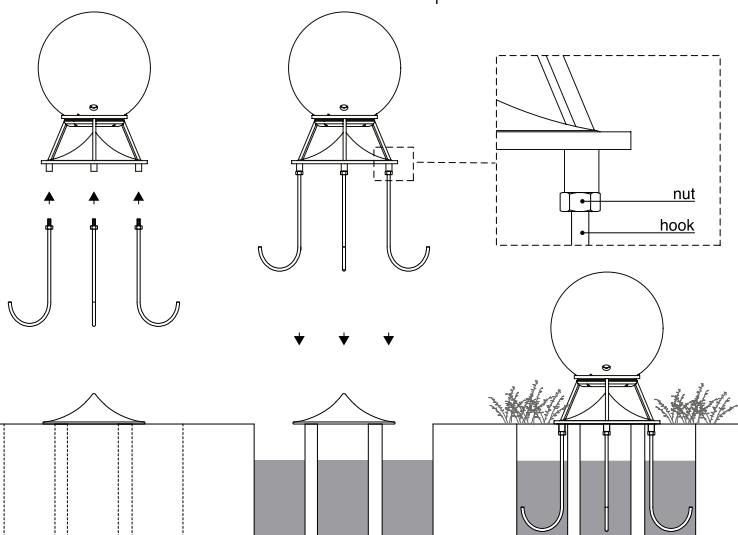

- Screw the hooks into the slots at the underside of the anti-theft base, secure them with hex-nuts.
- Dig three holes, approx. 50 cm deep, and fill them with concrete for approx. 2/3 of their depth.
- Place deflector in a central position, put hooks into holes till the base sits properly on deflector.
- Let concrete dry and fill holes with soil.

In the case of installations on hard floors, like stone or wood, AS provides a suitable anti-theft base as an accessory, which has 3 rings welded on its border, to secure it on the floor using the screws considered more appropriate by the installer according to the typology of the floor.

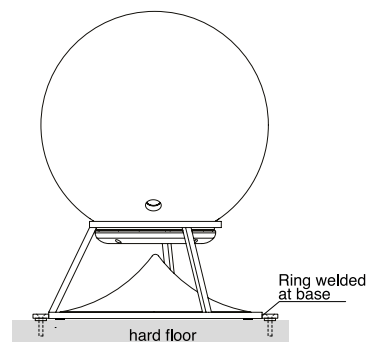

Maintenance and care: to keep your speakers beautiful as long as possible, we warmly recommend doing maintenance at least once a year. When not in use, sound modules should be appropriately covered or stored away; heavy duty protective covers are available from AS. Please refer to the General Manual for appropriate instructions and note that any departure from our recommendations on care and cleaning, or any evidence of misuse or damages from ordinary wear and tear, will void all warranty claims.